

PGR-6300 SERIES

Motor Protection System



1



2

MOTOR PROTECTION RELAYS

Description

The PGR-6300 Motor Protection System monitors voltage, current, and temperature (optional) to provide a comprehensive package of 22 protective functions. The PGR-6300 is a modular system with integrated protection, motor control, metering, and data-logging functions. This system is typically used to provide protection for three-phase low- and medium-voltage, medium- to high-horsepower induction motors.

1 Operator Interface

- Large, bright, 4 x 20 vacuum-fluorescent display
- Display metered values
- Keypad for motor control and menu selection
- Access set points
- Powered by Control Unit
- Panel mount or attach directly to Control Unit
- Remote mounting (1.2 km or 4000 ft maximum loop length)
- 1/2 DIN size
- Hazardous-location certified

2 Control Unit

- Current inputs—5-A or 1-A secondary phase current transformers
- Voltage inputs—up to 600 V without PTs
- Earth-leakage input—5-A or 1-A secondary or sensitive transformer
- Tachometer (high-speed pulse) input
- 8 digital inputs, 5 relay outputs, 1 analog input and output
- 24-Vdc supply for OPI and RTD modules, and for digital inputs
- IRIG-B time-code input
- 1/2 DIN size, surface mount
- RS-485 network communications
- DeviceNet™, Profibus®, or Ethernet communications available

Wiring Diagram

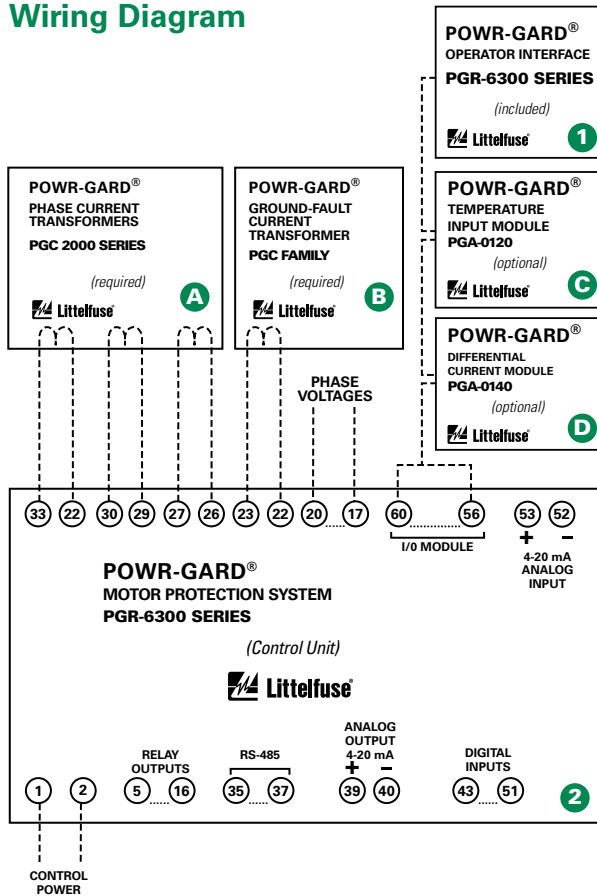

Accessories

A PGC-2000 Series Phase Current Transformers
Required CT detects phase current or ground-fault current (200-A primary). Other current ratios available.

B PGC Family Ground-Fault Transformers
Required zero-sequence current transformers detect ground-fault current. Available with 5-A and 30-A primary ratings for low-level pickup.

C PGA-0120 Temperature Input Module
Optional module provides 8 inputs to connect Pt100, Ni100, Ni120, and Cu10 RTDs.

D PGA-0140 Differential Current Module
Optional differential protection, compatible with core balance and summation current transformer connections.



Features & Benefits

FEATURES	IEEE #	BENEFITS
Overload	49, 51	Extends motor life and prevents insulation failures and fires
Current Unbalance/ Phase Loss/Phase Reverse	46	Prevents overheating and extends motor life
Overcurrent/Jam	50, 51	Prevents catastrophic failures and fires and extends motor life
Undercurrent	37	Detects low-level or no-load conditions
Ground Fault	50G/N, 51G/N	Prevents catastrophic failures and fires
RTD Temperature	38, 49	Optional RTD temperature protection (PGA-0120 module) for high ambient or loss of ventilation protection
Overvoltage	59	Prevents stress to insulation
Undervoltage	27	Prevents a start attempt when it will damage the motor
Voltage Unbalance	47	Detects unhealthy supply voltage
Phase Differential	87	Provides sensitive protection for high-resistance winding faults
Dynamic Thermal Model		Provides protection through starting, running, overload, and cooling cycles
Reduced Overcurrent Mode		Minimizes Arc-Flash hazards during maintenance
Starter Control		Simplifies the installation by reducing component count
Metering		Displays the measured and calculated motor parameters
Data Logging		On-board 64-event recorder helps with system diagnosis
Communications		Remotely view measured values, event records & reset trips
Conformal Coating		Internal circuits are conformally coated to protect against corrosion and moisture

Simplified Circuit Diagram

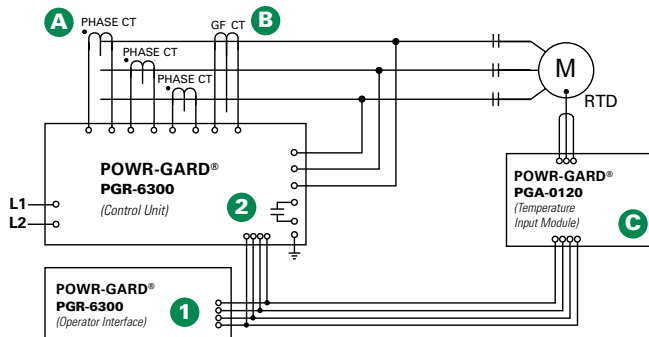

Ordering Information

CATALOG/ SYSTEM NUMBER	COMMUNICATIONS
PGR-6300-01-00	RS-485
PGR-6300-02-00	RS-485 & DeviceNet™
PGR-6300-03-00	RS-485 & Profibus®
PGR-6300-04-00	RS-485 & Ethernet

ACCESSORIES	REQUIREMENT	PAGE
PGC 2000 Series	Required	38
PGC Family	Required	38
PGA-0120	Optional	41
PGA-0140	Optional	41

Specifications

Protective Functions (IEEE Device Numbers)	Overload (49, 51)	Unbalance (current) (46)
	Phase reverse (current) (46)	Underspeed (14)
	Overfrequency (81)	Starts per hour (66)
	Overcurrent (50, 51)	Phase loss (voltage) (47)
	Jam	Overvoltage (59)
	Underfrequency (81)	Differential (87)
	Ground fault (50G/N, 51G/N)	Phase loss (current) (46)
	Undercurrent (37)	Undervoltage (27)
	Unbalance (voltage) (47)	Phase reverse (voltage) (47)
	Failure to accelerate	Power factor (55)
	RTD temperature (38, 49)	
	Input Voltage	65 – 265 Vac, 25 VA; 80-275 Vdc, 25 W
	Power-Up Time	800 ms at 120 Vac
	Ride-Through Time	100 ms minimum
24-Vdc Source	100 mA maximum	
AC Measurements	True RMS and DFT, Peak, 16 samples/cycle, and positive and negative sequence of fundamental 50, 60 Hz or ASD	
Frequency Inputs	Phase-current, Earth-leakage current, Phase-voltage, 7 digital, tachometer, 1 analog	
Output Contacts	5 contacts — See Product Manual	
Approvals	CSA certified to US and Canadian standards	
Communications	Allen-Bradley® DFI and Modbus® RTU (Standard); DeviceNet™, Profibus®, Ethernet (Optional)	
Conformally Coated	Standard feature	
Warranty	10 years	
Mounting (Control Unit)	Surface	
(Operator Interface)	Panel	